

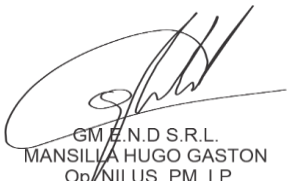

	INFORME DE I.N.D		Nº 17.548																	
	CONTROL DE POZO		HOJA 1 de 5																	
CATEGORIA INSPECCIÓN		IV																		
PROCEDIMIENTO: PO-45 <input checked="" type="checkbox"/>	CLIENTE: CAM SRL	FECHA:	21	03	2026															
PRÁCTICA DEL CLIENTE: <input type="checkbox"/>	Nº PARTE: 4.138	LUGAR DE INSPECCIÓN:	BASE CLIENTE																	
MARCA: SAYI	MODELO: N/A	CAPACIDAD:	25 MTS 3																	
INTERNO: #CL 54	DOMINIO: AB-930-US	VIGENCIA:	12 MESES																	
Inspección a metal limpio: Arenado <input type="checkbox"/> Limpieza Mecánica <input checked="" type="checkbox"/> Inspe. Us Cisterna <input checked="" type="checkbox"/> Cisterna <input checked="" type="checkbox"/> Línea <input checked="" type="checkbox"/> Falla <input checked="" type="checkbox"/> Espesor <input checked="" type="checkbox"/> Prueba de Estanqueidad Cisterna Si <input checked="" type="checkbox"/> No <input checked="" type="checkbox"/> <u>Prueba Hidráulica:</u> Válvula de Seguridad <input checked="" type="checkbox"/> Presión de Diseño <table border="1" style="display: inline-table; vertical-align: middle;"><tr><td>N/A</td><td>PSI</td></tr><tr><td>Presión de Prueba</td><td>N/A</td><td>PSI</td></tr></table> Línea <input checked="" type="checkbox"/> Presión de Diseño <table border="1" style="display: inline-table; vertical-align: middle;"><tr><td>N/A</td><td>PSI</td></tr><tr><td>Presión de Prueba</td><td>N/A</td><td>PSI</td></tr></table> Manguerote <input checked="" type="checkbox"/> Presión de Diseño <table border="1" style="display: inline-table; vertical-align: middle;"><tr><td>3000</td><td>PSI</td></tr><tr><td>Presión de Prueba</td><td>3000</td><td>PSI</td></tr></table>						N/A	PSI	Presión de Prueba	N/A	PSI	N/A	PSI	Presión de Prueba	N/A	PSI	3000	PSI	Presión de Prueba	3000	PSI
N/A	PSI																			
Presión de Prueba	N/A	PSI																		
N/A	PSI																			
Presión de Prueba	N/A	PSI																		
3000	PSI																			
Presión de Prueba	3000	PSI																		
EQUIPO UTILIZADO																				
EQUIPO UTILIZADO	Nº DE SERIE / LOTE	Nº DE CERTIFICADO	F. CALIBRACIÓN	F. DE VENCIMIENTO																
LÁMPARA UV	9296	61245	19/5/2025	may-30																
YUGO	0586	61246	6/5/2025	may-30																
EQUIPO UT1	202000541886	61239	8/5/2025	8/5/2026																
BOBINA AC-DC	1414	61248	21/5/2025	21/5/2026																
MEDIDOR DE CAMPO	GM 064	NO APLICA	NO APLICA	NO APLICA																
PARTICULAS S/H	2101005648	NO APLICA	1/6/2021	1/6/2026																
MASA PATRON	864	45944	1/8/2023	1/8/2028																
DETALLE DE INSPECCIÓN																				
DESCRIPCIÓN	APTO	NO APTO																		
Detección de Fisuras	<input checked="" type="checkbox"/>	<input type="checkbox"/>																		
Estado de Golpeador	<input checked="" type="checkbox"/>	<input type="checkbox"/>																		
Estado de Línea	<input checked="" type="checkbox"/>	<input type="checkbox"/>																		
Estado de Cisterna	<input checked="" type="checkbox"/>	<input type="checkbox"/>																		
Estado General	<input checked="" type="checkbox"/>	<input type="checkbox"/>																		
Aprobación según procedimiento Nº PO-45 ASME V;B 31.3 ;API 570; ASTM-797			SI																	
DETALLE DE TAREAS REALIZADAS - OBSERVACIONES - COMENTARIOS																				
 GM E.N.D S.R.L. MANSILLA HUGO GASTON Op/NII US. PM. LP		PRECINTO Nº																		
		FECHA PUESTA EN VIGENCIA																		
FIRMA OPERADOR GM END S.R.L.		FIRMA CLIENTE - ACLARACIÓN		FIRMA - ACLARACIÓN																

	INFORME DE I.N.D			Nº 17.548						
	CONTROL DE POZO			HOJA 2 de 5						
						W.O.				
PROCEDIMIENTO:	PO-45	X	CLIENTE:	CAM SRL			FECHA:	21	03	2026
PRÁCTICA DEL CLIENTE:	0		Nº PARTE:	4.138			LUGAR DE INSPECCIÓN:	BASE CLIENTE		



MEDICIÓN DE ESPESORES POR ULTRASONIDO EN:						Milímetros (mm)
Punto	CASQUETE A	CASQUETE B	S1	S2	S3	S4
1	6,1	6,6	6,0	6,4	6,3	6,0
2	6,0	6,5	6,1	6,3	6,2	6,0
3	6,3	6,3	6,3	6,3	6,1	6,1
4	6,1	6,5	6,2	6,4	6,3	6,1
5	6,3	6,4	6,3	6,2	6,5	6,3
6	6,1	6,3	6,0	6,0	6,3	6,0
7	6,5	6,4	6,2	6,1	6,1	6,1
8	6,3	6,3	6,4	6,4	6,2	6,3
9	6,3	6,2	6,3	6,5	6,3	6,2

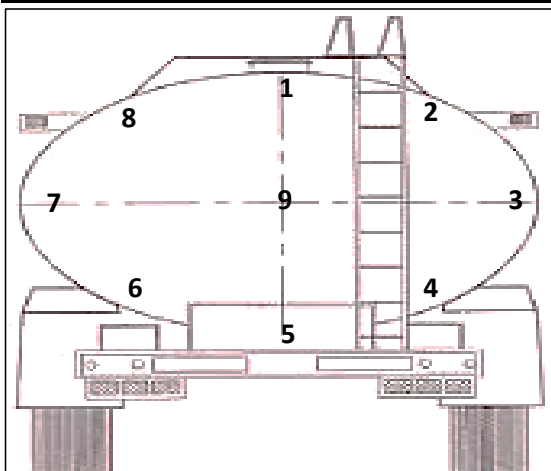

 GM E.N.D S.R.L. MANSILLA HUGO GASTON Op/NII US. PM. LP		PRECINTO Nº	
		FECHA PUESTA EN VIGENCIA	
FIRMA OPERADOR GM END S.R.L.	FIRMA CLIENTE - ACLARACIÓN	FIRMA - ACLARACIÓN	

CALLE 3275 N°277 BARRIO ACCESO SUR/PARQUE INDUSTRIAL- CHUBUT-9000 - CEL: (0297) 15-6256447-Email: mansilla.end@gmail.com

	INFORME DE I.N.D	N° 17.548
	CONTROL DE POZO	HOJA 3 de 5
		W.O.

PROCEDIMIENTO: PO-45 X	CLIENTE: CAM SRL	FECHA: 21 / 03 / 2026
-------------------------------	-------------------------	--

PRÁCTICA DEL CLIENTE: 0	N° PARTE: 4.138	LUGAR DE INSPECCIÓN: BASE CLIENTE
--------------------------------	------------------------	--

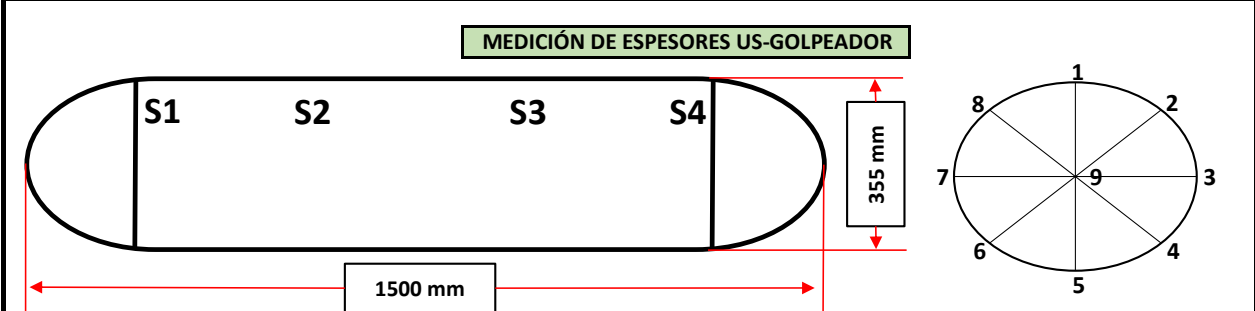

MEDICIÓN DE ESPESORES POR ULTRASONIDO EN:						Milímetros (mm)
Punto	CASQUETE A	CASQUETE B	S1	S2	S3	S4
1	9,0	9,1	9,3	9,2	9,0	-
2	9,1	9,1	9,2	9,1	9,2	-
3	8,9	9,0	8,9	9,3	9,1	-
4	8,9	9,0	9,1	9,2	9,3	-



VALVULA DE VENTEO	
N°	101
∅	4"
PH	0,5 KG/CM ²



VALVULA DE SEGURIDAD	
Ap	1250 psi
PRECINTO	N/A

 GM E.N.D S.R.L. MANSILLA HUGO GASTON Op/NII US. PM. LP		PRECINTO N°	
			FECHA PUESTA EN VIGENCIA
	FIRMA OPERADOR GM END S.R.L.	FIRMA CLIENTE - ACLARACIÓN	FIRMA - ACLARACIÓN

CALLE 3275 N°277 BARRIO ACCESO SUR/PARQUE INDUSTRIAL- CHUBUT-9000 - CEL: (0297) 15-6256447-Email: mansilla.end@gmail.com

	INFORME DE I.N.D		Nº 17.548 HOJA 4 de 5 W.O.		
	CONTROL DE POZO				
PROCEDIMIENTO: PO-45 x	CLIENTE: CAM SRL		FECHA: 21 03 2026		
PRÁCTICA DEL CLIENTE: 0	Nº PARTE: 4.138	LUGAR DE INSPECCIÓN: BASE CLIENTE			

MEDICIÓN DE ESPESORES POR ULTRASONIDO (EN mm)

DESCRIPCIÓN	1	2	3	4
PLANO A	8,7	8,5	8,6	8,6
PLANO B	8,9	8,7	9	8,9
PLANO C	9,1	9	8,7	8,8
PLANO D	9	8,7	8,8	9
PLANO E	8,7	8,9	9,1	9,1
PLANO F	9,1	8,8	8,9	8,9
PLANO G	9,1	8,8	8,9	9,1
PLANO H	8,7	8,8	8,8	8,9
PLANO I	9	9,1	9,1	9
PLANO J	9	8,9	9,1	8,9
PLANO K	9	8,9	9,1	9,1
PLANO L	9,3	8,9	9	8,9
PLANO M	9,2	8,8	9	8,8
PLANO N	9,2	9	8,9	9,2
PLANO Ñ	9	9	9,1	9,2
PLANO O	9,1	8,9	9,1	8,9
PLANO P	9,1	9,1	8,9	8,9
PLANO Q	9	9,1	8,9	9,1
PLANO R	9	9,1	9,1	9,1

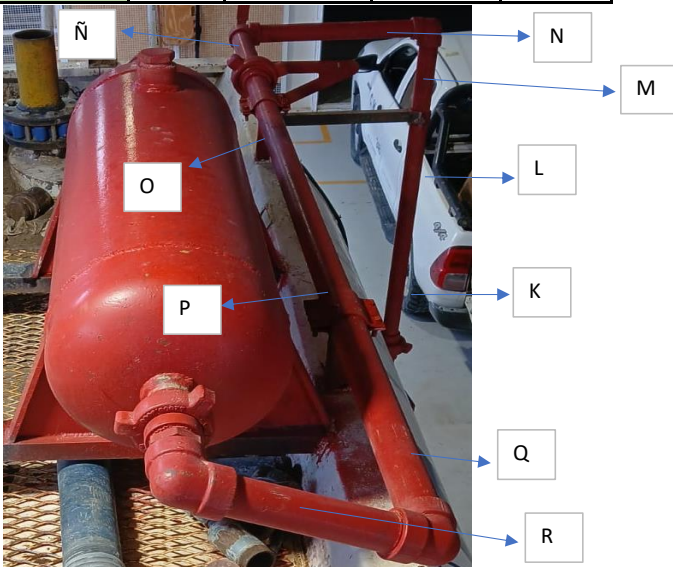
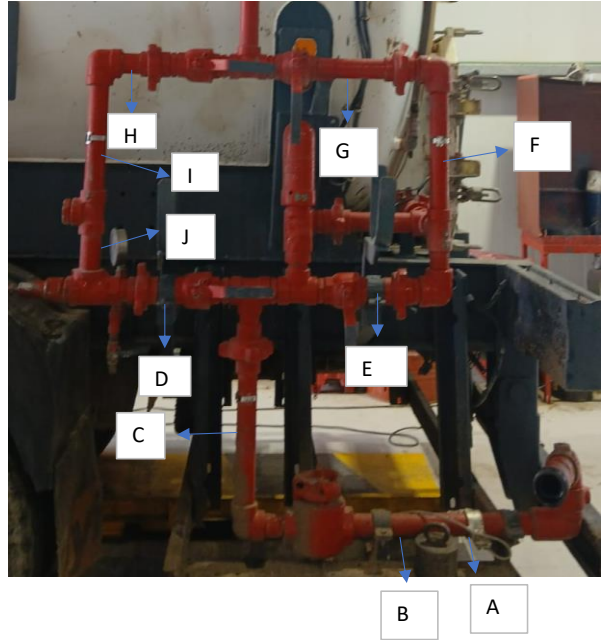

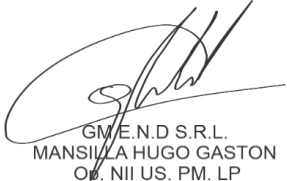
 GM E.N.D S.R.L. MANSILLA HUGO GASTON Op. NII US. PM. LP		PRECINTO Nº
		FECHA PUESTA EN VIGENCIA
FIRMA OPERADOR GM END S.R.L.	FIRMA CLIENTE - ACLARACIÓN	FIRMA - ACLARACIÓN

CALLE 3275 N°277 BARRIO ACCESO SUR/PARQUE INDUSTRIAL- CHUBUT-9000 - CEL: (0297) 15-6256447-Email: mansilla.end@gmail.com

	INFORME DE I.N.D	Nº 17.548
	CONTROL DE POZO	HOJA 5 de 5 W.O.

PROCEDIMIENTO: PO-45 <input checked="" type="checkbox"/>	CLIENTE: CAM SRL	FECHA: <table border="1" style="display: inline-table; border-collapse: collapse;"><tr><td style="width: 20px;">21</td><td style="width: 20px;">03</td><td style="width: 20px;">2026</td></tr></table>	21	03	2026
21	03	2026			

PRÁCTICA DEL CLIENTE: 0	Nº PARTE: 4.138	LUGAR DE INSPECCIÓN: BASE CLIENTE
--------------------------------	------------------------	--

MANGUEROTE

LONGITUD	15 MTS
PH	3000
Nº IDENT	#54
DIÁMETRO	49,8 MM
APROBADO	SI <input checked="" type="checkbox"/> NO <input type="checkbox"/>



PERNO REY

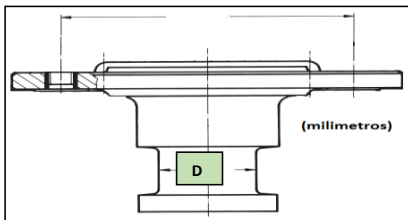

MARCA	JOST
CAPACIDAD	N/A
Nº IDENT	#54
DIÁMETRO	∅ 49,8"
APROBADO	SI <input checked="" type="checkbox"/> NO <input type="checkbox"/>

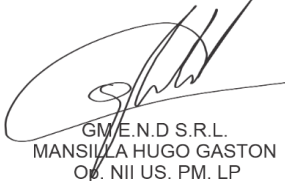

 GM E.N.D S.R.L. MANSILLA HUGO GASTON Op. NII US. PM. LP		PRECINTO Nº
		FECHA PUESTA EN VIGENCIA
FIRMA OPERADOR GM END S.R.L.	FIRMA CLIENTE - ACLARACIÓN	FIRMA - ACLARACIÓN

CALLE 3275 N°277 BARRIO ACCESO SUR/PARQUE INDUSTRIAL- CHUBUT-9000 - CEL: (0297) 15-6256447-Email: mansilla.end@gmail.com