

	<b>INFORME DE I.N.D</b>	<b>Nº 17.238</b> HOJA 2 de 2
	<b>EQUIPO DE AGUA POTABLE</b>	w.o.

PROCEDIMIENTO:	PO-63	x	CLIENTE:	CAM SRL	FECHA:	07	02	2026
----------------	-------	---	----------	---------	--------	----	----	------

PRÁCTICA DEL CLIENTE:	0	Nº PARTE:	4.042	LUGAR DE INSPECCIÓN:	BASE GM END S.R.L.
-----------------------	---	-----------	-------	----------------------	--------------------

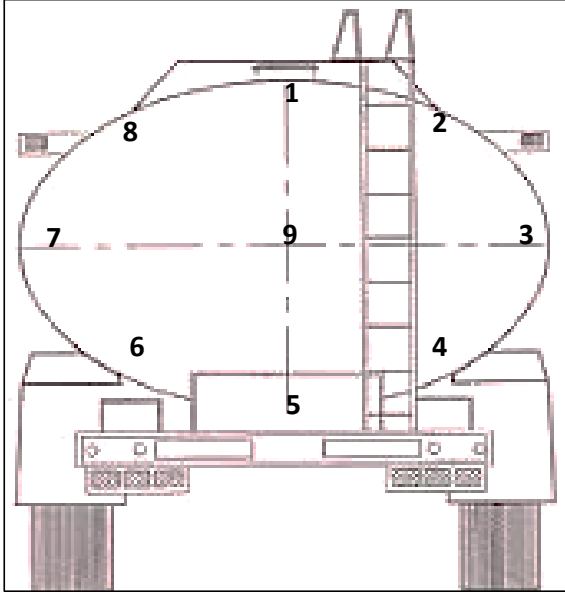

 GM E.N.D S.R.L. MANSILLA HUGO GASTON Op/NII US. PM. LP FIRMA OPERADOR GM END S.R.L.		PRECINTO Nº		
		FECHA PUESTA EN VIGENCIA		
		FIRMA - ACLARACIÓN		

CALLE 3275 N°277 BARRIO ACCESO SUR/PARQUE INDUSTRIAL- CHUBUT-9000 - CEL: (0297) 15-6256447-Email: mansilla.end@gmail.com