

	INFORME DE I.N.D		Nº 17.119													
	CONTROL DE POZO		HOJA 1 de 5													
CATEGORIA INSPECCIÓN IV																
PROCEDIMIENTO: PO-45 <input checked="" type="checkbox"/>	CLIENTE: CAM SRL	FECHA: 19 / 07 / 2025														
PRÁCTICA DEL CLIENTE: <input type="checkbox"/>	Nº PARTE: 3.756	LUGAR DE INSPECCIÓN: BASE CLIENTE														
MARCA: SAYI	MODELO: N/A	CAPACIDAD: 25 MTS3														
INTERNO: #CL 81	DOMINIO: AF-448-VV	VIGENCIA: 12 MESES														
Inspección a metal limpio: Arenado <input type="checkbox"/> Limpieza Mecánica <input checked="" type="checkbox"/> Inspe. Us Cisterna <input checked="" type="checkbox"/> Cisterna <input checked="" type="checkbox"/> Línea <input checked="" type="checkbox"/> Falla <input checked="" type="checkbox"/> Espesor <input checked="" type="checkbox"/> Prueba de Estanqueidad Cisterna Si <input type="checkbox"/> No <input checked="" type="checkbox"/> <u>Prueba Hidráulica:</u> Válvula de Seguridad <input checked="" type="checkbox"/> Presión de Diseño <table border="1" style="display: inline-table; vertical-align: middle;"><tr><td>1500</td><td>PSI</td></tr><tr><td>1500</td><td>PSI</td></tr></table> Línea <input checked="" type="checkbox"/> Presión de Diseño <table border="1" style="display: inline-table; vertical-align: middle;"><tr><td>2500</td><td>PSI</td></tr><tr><td>2500</td><td>PSI</td></tr></table> Manguerote <input checked="" type="checkbox"/> Presión de Diseño <table border="1" style="display: inline-table; vertical-align: middle;"><tr><td>3000</td><td>PSI</td></tr><tr><td>3000</td><td>PSI</td></tr></table>					1500	PSI	1500	PSI	2500	PSI	2500	PSI	3000	PSI	3000	PSI
1500	PSI															
1500	PSI															
2500	PSI															
2500	PSI															
3000	PSI															
3000	PSI															
EQUIPO UTILIZADO																
EQUIPO UTILIZADO	Nº DE SERIE / LOTE	Nº DE CERTIFICADO	F. CALIBRACIÓN	F. DE VENCIMIENTO												
LÁMPARA UV	9296	61245	19/5/2025	may-30												
YUGO	0586	61246	6/5/2025	may-30												
EQUIPO UT1	202000541886	61239	22/12/2024	22/12/2025												
BOBINA AC-DC	1414	61248	21/5/2025	21/5/2026												
MEDIDOR DE CAMPO	GM 064	NO APLICA	NO APLICA	NO APLICA												
PARTICULAS S/H	2101005648	NO APLICA	1/6/2021	1/6/2026												
MASA PATRON	864	45944	1/8/2023	1/8/2028												
DETALLE DE INSPECCIÓN																
DESCRIPCIÓN	APTO	NO APTO														
Detección de Fisuras	<input checked="" type="checkbox"/>	<input type="checkbox"/>														
Estado de Golpeador	<input checked="" type="checkbox"/>	<input type="checkbox"/>														
Estado de Línea	<input checked="" type="checkbox"/>	<input type="checkbox"/>														
Estado de Cisterna	<input checked="" type="checkbox"/>	<input type="checkbox"/>														
Estado General	<input checked="" type="checkbox"/>	<input type="checkbox"/>														
																
Aprobación según procedimiento Nº PO-45 ASME V;B 31.3 ;API 570; ASTM-797			SI													
DETALLE DE TAREAS REALIZADAS - OBSERVACIONES - COMENTARIOS																
 GM E.N.D S.R.L. MANSILLA HUGO GASTON Op/NII US. PM. LP		PRECINTO Nº														
FIRMA OPERADOR GM END S.R.L.		FIRMA CLIENTE - ACLARACIÓN	FECHA PUESTA EN VIGENCIA													
		FIRMA - ACLARACIÓN														

CALLE 3275 N°277 BARRIO ACCESO SUR/PARQUE INDUSTRIAL- CHUBUT-9000 - CEL: (0297) 15-6256447-Email: mansilla.end@gmail.com

	INFORME DE I.N.D		Nº 17.119 HOJA 2 de 5 W.o.		
	CONTROL DE POZO				
PROCEDIMIENTO: PO-45 <input checked="" type="checkbox"/>	CLIENTE: CAM SRL	FECHA:	19	07	2025
PRÁCTICA DEL CLIENTE: 0	Nº PARTE: 3.756	LUGAR DE INSPECCIÓN:	BASE CLIENTE		

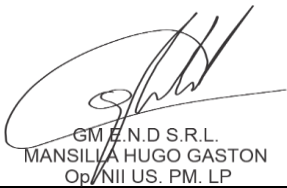

MEDICIÓN DE ESPESORES POR ULTRASONIDO EN:						Milímetros (mm)
Punto	CASQUETE A	CASQUETE B	S1	S2	S3	S4
1	6,6	6,6	6,5	6,4	6,6	6,3
2	6,5	6,4	6,2	6,4	6,4	6,3
3	6,3	6,2	6,3	6,3	6,5	6,4
4	6,2	6,6	6,2	6,2	6,6	6,5
5	6,1	6,6	6,2	6,6	6,2	6,3
6	6,4	6,2	6,1	6,5	6,6	6,1
7	6,5	6,5	6,0	6,3	6,5	6,6
8	6,2	6,5	6,6	6,5	6,4	6,6
9	6,1	6,3	6,5	6,3	6,4	6,5

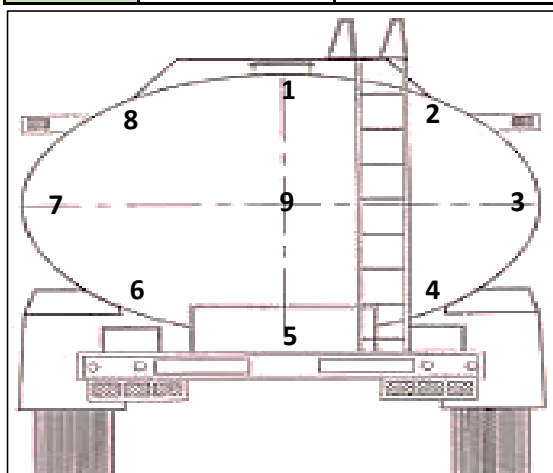

 GM E.N.D S.R.L. MANSILLA HUGO GASTON Op/NII US. PM. LP		PRECINTO Nº		
		FIRMA OPERADOR GM END S.R.L.	FIRMA CLIENTE - ACLARACIÓN	FIRMA - ACLARACIÓN

CALLE 3275 N°277 BARRIO ACCESO SUR/PARQUE INDUSTRIAL- CHUBUT-9000 - CEL: (0297) 15-6256447-Email: mansilla.end@gmail.com

	INFORME DE I.N.D	Nº 17.119
	CONTROL DE POZO	HOJA 3 de 5
		W.O.

PROCEDIMIENTO: PO-45 X	CLIENTE: CAM SRL	FECHA: 19 07 2025
-------------------------------	-------------------------	--------------------------

PRÁCTICA DEL CLIENTE: 0	Nº PARTE: 3.756	LUGAR DE INSPECCIÓN: BASE CLIENTE
--------------------------------	------------------------	--

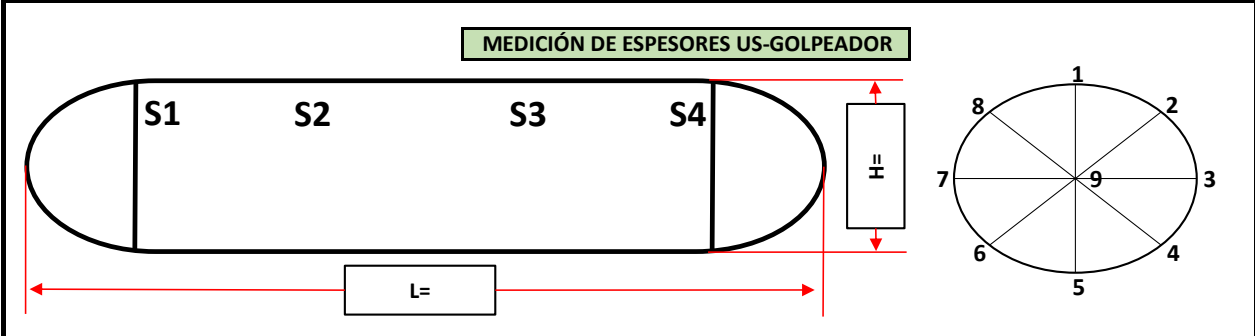

MEDICIÓN DE ESPESORES POR ULTRASONIDO EN:						Milímetros (mm)
Punto	CASQUETE A	CASQUETE B	S1	S2	S3	S4
1	11,9	12,1	12,0	11,8	12,2	-
2	11,0	12,1	12,1	11,9	12,0	-
3	9,7	9,8	9,6	9,9	9,7	-
4						-



VALVULA DE VENTEO	
Nº	81-1
Ø	4
PH	500 GRS



VALVULA DE VENTEO	
Nº	81-2
Ø	4
PH	500 GRS



VALVULA DE SEGURIDAD	
Ap	1500 PSI
PRECINTO	#CL-81

 GM E.N.D S.R.L. MANSILLA HUGO GASTON Op/NII US. PM. LP		PRECINTO Nº
FIRMA OPERADOR GM END S.R.L.	FIRMA CLIENTE - ACLARACIÓN	FIRMA - ACLARACIÓN

CALLE 3275 N°277 BARRIO ACCESO SUR/PARQUE INDUSTRIAL- CHUBUT-9000 - CEL: (0297) 15-6256447-Email: mansilla.end@gmail.com

	INFORME DE I.N.D		Nº 17.119 HOJA 4 de 5 W.O.	
	CONTROL DE POZO			
PROCEDIMIENTO: PO-45 x	CLIENTE: CAM SRL	FECHA: 19 07 2025		
PRÁCTICA DEL CLIENTE: 0	Nº PARTE: 3.756	LUGAR DE INSPECCIÓN: BASE CLIENTE		

MEDICIÓN DE ESPESORES POR ULTRASONIDO (EN mm)

DESCRIPCIÓN	1	2	3	4
PLANO A	5	5,2	5,1	5,6
PLANO B	5,2	5,4	5,3	5,7
PLANO C	5,3	5,2	5,6	5,5
PLANO D	5,2	5,3	5,5	5,6
PLANO E	5,3	5,7	5,7	5,7
PLANO F	5,2	5,5	5,8	5,5
PLANO G	5,2	5,4	5,3	5,5
PLANO H	5,6	5,6	5,4	5,4
PLANO I	5,3	5,7	5,6	5,6
PLANO J	5,4	5,7	5,6	5,4
PLANO K	5,7	5,6	5,7	5,7
PLANO L	5,4	5,2	5,8	5,6
PLANO M	5,2	5,3	5,5	5,6
PLANO N	5,3	5,7	5,7	5,7
PLANO Ñ	5,2	5,5	5,8	5,5
PLANO O	5,2	5,4	5,3	5,5
PLANO P	5,3	5,7	5,6	5,6
PLANO Q	5,4	5,7	5,6	5,4
PLANO R	5,2	5,3	5,5	5,6

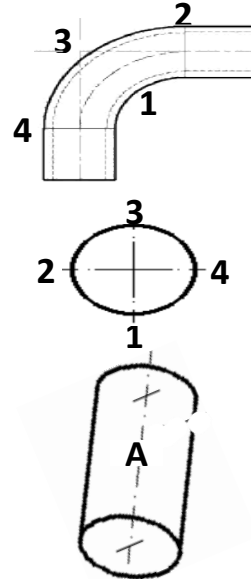

 GM E.N.D S.R.L. MANSILLA HUGO GASTON OP. NII US. PM. LP		PRECINTO Nº	
		FECHA PUESTA EN VIGENCIA	
FIRMA OPERADOR GM END S.R.L.	FIRMA CLIENTE - ACLARACIÓN	FIRMA - ACLARACIÓN	

CALLE 3275 N°277 BARRIO ACCESO SUR/PARQUE INDUSTRIAL- CHUBUT-9000 - CEL: (0297) 15-6256447-Email: mansilla.end@gmail.com

	INFORME DE I.N.D	Nº 17.119
	CONTROL DE POZO	HOJA 5 de 5 W.O.

PROCEDIMIENTO: PO-45 <input checked="" type="checkbox"/>	CLIENTE: CAM SRL	FECHA: 19 / 07 / 2025
---	-------------------------	--

PRÁCTICA DEL CLIENTE: 0	Nº PARTE: 3.756	LUGAR DE INSPECCIÓN: BASE CLIENTE
--------------------------------	------------------------	--

MANGUEROTE

LONGITUD	13 METROS	
PH	3000 PSI	
Nº IDENT	#81-3	
DIÁMETRO	2"	
APROBADO	SI <input checked="" type="checkbox"/>	NO <input type="checkbox"/>



PERNO REY

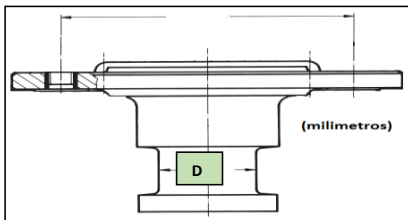

MARCA	N/A	
CAPACIDAD	65 TONELADAS	
Nº IDENT	#81-1	
DIÁMETRO	Ø 50,3"	
APROBADO	SI <input checked="" type="checkbox"/>	NO <input type="checkbox"/>

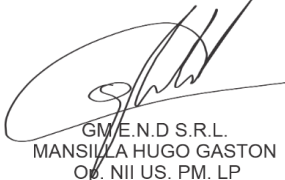

 GM E.N.D S.R.L. MANSILLA HUGO GASTON Op. NII US. PM. LP		PRECINTO Nº	
		FECHA PUESTA EN VIGENCIA	
FIRMA OPERADOR GM END S.R.L.	FIRMA CLIENTE - ACLARACIÓN	FIRMA - ACLARACIÓN	

CALLE 3275 Nº277 BARRIO ACCESO SUR/PARQUE INDUSTRIAL- CHUBUT-9000 - CEL: (0297) 15-6256447-Email: mansilla.end@gmail.com